

SET-1000 12 VDC

Level switch for one sensor



Installation and Operating Instructions



TABLE OF CONTENTS

1	GENERAL.....	3
2	INSTALLATION	4
2.1	Cabling when using cable junction box.....	5
2.2	Cabling when using cable joint	6
3	OPERATION AND SETTINGS.....	7
3.1	Operation	7
3.2	Altering settings.....	8
4	TROUBLE-SHOOTING	10
5	REPAIR AND SERVICE	10
6	SAFETY INSTRUCTIONS.....	11
	APPENDICES.....	12
	Appendix 1 Technical data	12
	Appendix 2 Electrical parameters.....	13

SYMBOLS



Warning / Attention



Pay special attention to installations at explosive atmospheres



Device is protected by double or reinforced insulation

1 GENERAL

SET-1000 is a one-channel level switch. Typical applications are high level and low level alarms in liquid tanks, condensed water alarms, level control and alarms in oil, sand and grease separators.

The LED indicators, push buttons and interfaces of the device are described in figure 1.



SET-1000 user interface features:

- ① LED indicator for mains
- ② LED indicators of alarm and fault
- ③ Reset button for alarm and fault
- ④ Test button
- ⑤ Connector for one Labkotec SET level sensor [Ex ia]
- ⑥ Potential-free relay outputs for monitoring and control purposes

Figure 1. SET-1000 level switch – features

SET-1000 can be used as a controller of a level sensor located in potentially explosive atmosphere (zone 0,1 or 2) due to intrinsically safe inputs of the device. The SET-1000 itself must be installed in a non-hazardous area.

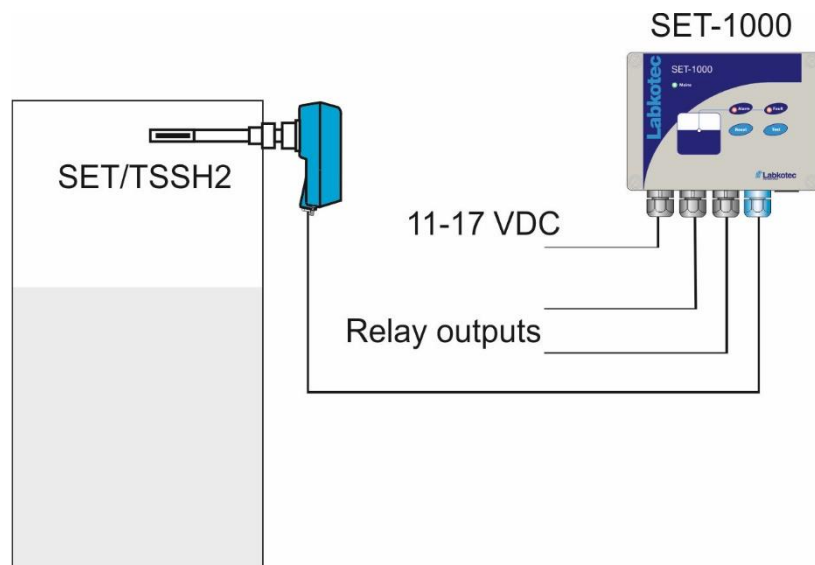

Figure 2. Typical application. High level alarm in a liquid vessel.

2 INSTALLATION

The SET-1000 can be wall-mounted. The mounting holes are located in the base plate of the enclosure, beneath the mounting holes of the front cover.

The connectors of the external conductors are isolated by separating plates. The plates must not be removed. The plate covering the connectors must be installed back after executing cable connections.

The cover of the enclosure must be tightened so, that the edges touch the base frame. Only then do the push buttons function properly and the enclosure is tight.

Before installation, please read the safety instructions in chapter 6 !

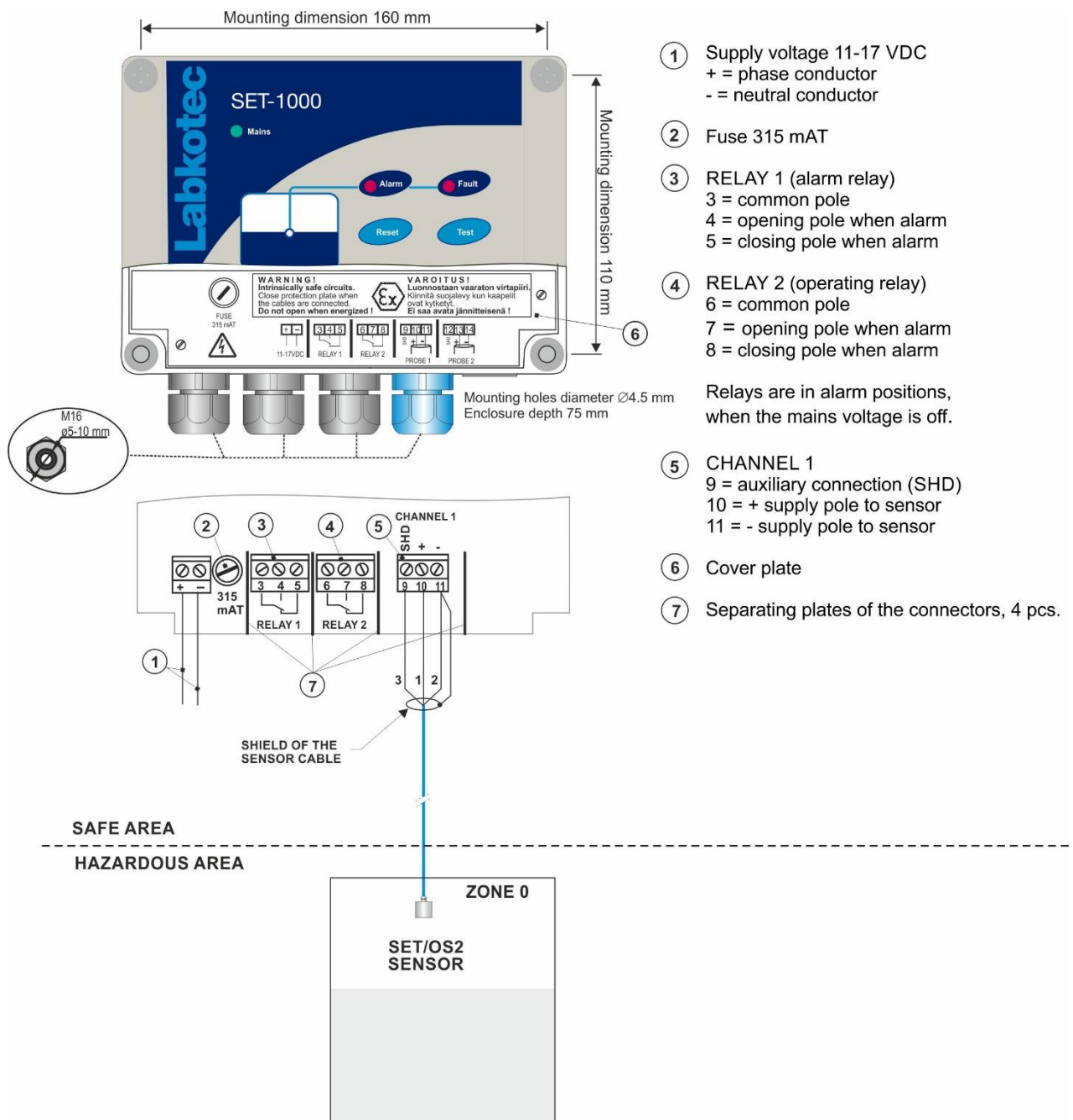

Figure 3. SET-1000 installation and connections of SET/OS2 sensor.

2.1 Cabling when using cable junction box

If the sensor cable must be extended or there is need for equipotential grounding, it can be done with the cable junction box. The cabling between the SET-1000 control unit and the junction box should be done with a shielded twisted pair instrument cable.

LJB2 junction box enables cable extension in potentially explosive atmospheres.

In examples in figure 4 the shields and excess wires have been connected to the same point in galvanic contact with metallic frame of the junction box. This point can be connected to equipotential ground thru the ground terminal. Other components of the system that need to be grounded can also be connected to the same ground terminal.

The wire used for equipotential grounding must be min. 2.5 mm² mechanically protected or, when not protected, the minimum cross section is 4 mm².

Please make sure, that the cable between SET-1000 and the sensor does not exceed maximum connection values – see appendix 2.

Detailed cabling instructions can be found in the instructions of particular Labkotec SET sensors.

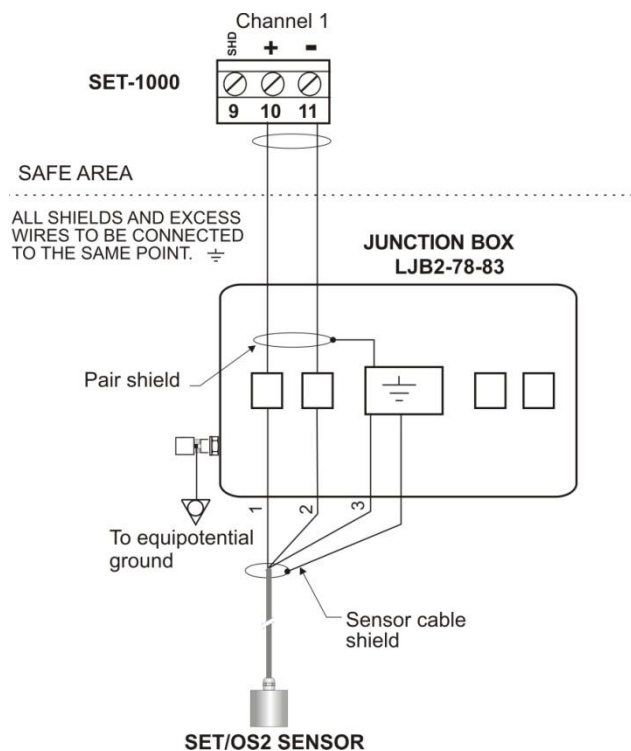

Figure 4. Level sensor cabling with a junction box for cable extension.



Junction box of type LJB2 include light alloy parts. When installing in explosive atmosphere, make sure, that the junction box is located so, that it can not be mechanically damaged or it will not be exposed to external impacts, friction etc. causing ignition of sparks.

Make sure, that the junction box is closed properly.

2.2 Cabling when using cable joint



Figure 5. Cable joint

Connections of the sensor cable inside the cable joint are explained in figure 8. Cable shields and possible excess wires need to be connected to the same point in galvanic contact.

Please make sure, that the sensor and cable between SET-1000 control unit and the sensor do not exceed the maximum allowed electrical parameters – see appendix 1 Technical data.

IP rating of the cable joint is IP68. Make sure, that the cable joint is closed properly.

If the sensor cable must be extended and there is a need for equipotential grounding, it should be done with the junction box LJB2. The cabling between the SET-1000 control unit and the junction box should be done with a shielded twisted pair instrument cable.



Figure 6. Cable installation example



Figure 7. Installation accessories

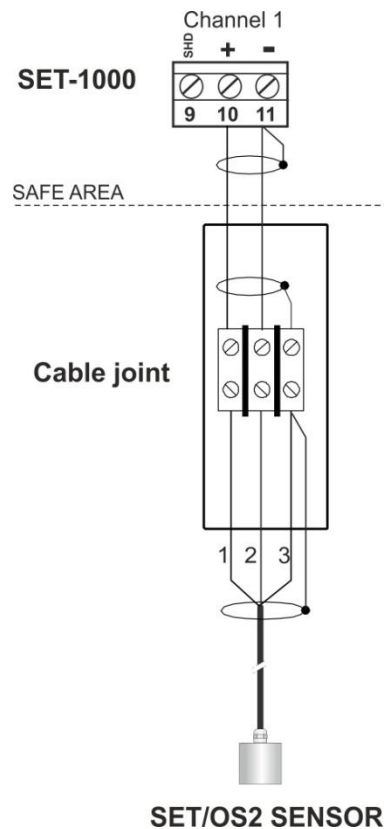

Figure 8. Level sensor cabling with a cable joint for cable extension.

3 OPERATION AND SETTINGS

The SET-1000 control unit is initialized at the factory as follows. See a more detailed description in chapter 3.1 *Operation*.

Channel 1 Alarm takes place when the level hits the sensor (high level alarm)

Relay 1 Relay de-energizes in alarm and fault situations (so-called fail-safe operation).
Relay 1 is resettable with the Reset button.

Relay 2 Relay de-energizes in alarm and fault situations (so-called fail-safe operation).

Operational delay for both relays is set to 5 seconds. The trigger level is normally at the middle of the sensor's sensing element.

3.1 Operation

The operation of a factory-initialized SET-1000 is described in this chapter.

If the operation is not as described here, check the settings (chapter 3.2.) and the operation (chapter 4) or contact a representative of the manufacturer.

<i>Normal mode – no alarms</i>	<i>The level in the tank is below the sensor. Mains LED indicator is on. Other LED indicators are off. Relays 1 and 2 are energized.</i>
<i>High level alarm</i>	<i>The level has hit the sensor (sensor in the medium). Mains LED indicator is on. Alarm LED indicator is on. Buzzer on after 5 sec delay. Relays de-energize after 5 sec delay.</i>
<i>Fault alarm</i>	<i>Sensor cable break, short circuit or a broken sensor, i.e. too low or too high sensor signal current. Mains LED indicator is on. Sensor cable Fault LED indicator is on after 5 sec delay. The relays de-energize after 5 sec delay. Buzzer is on after 5 sec delay.</i>
<i>Reset of an alarm</i>	<i>When pressing the Reset push button. Buzzer will go off. Relay 1 energizes. Relay 2 will stay de-energized until the actual alarm or fault is off.</i>

TEST FUNCTION

Test function provides an artificial alarm, which can be used to test the function of the SET-1000 level switch and the function of other equipment, which is connected to SET-1000 via its relays.



Attention ! Before pressing the Test button, make sure that the change of relay status does not cause hazards elsewhere !

<i>Normal situation</i>	<p><i>When pressing the Test push button:</i> Alarm and Fault LED indicators are immediately on. Buzzer is immediately on. Relays de-energize after 2 sec of continuous pressing.</p> <p><i>When the Test push button is released:</i> LED indicators and buzzer go immediately off. Relays energize immediately.</p>
<i>Alarm on</i>	<p><i>When pressing the Test push button:</i> Fault LED indicator is immediately on. Alarm LED indicator remains on. Buzzer remains on. If it has been reset earlier, it will return to be on. If relay 1 was already reset, it will de-energize again after 2 sec. of continuous pressing. Test will not affect relay 2, because it is already in alarm status.</p> <p><i>When the Test push button is released:</i> The device returns without delay to the preceding status.</p>
<i>Fault alarm on</i>	<p><i>When pressing the Test push button:</i> The device does not react to the test at all.</p>

3.2 Altering settings

If the default situation described above does not apply to the site being measured, the following device settings can be changed.

- Operating direction* High level or low level function (increasing or decreasing level).
- Operation delay* Two alternatives: 5 sec or 30 sec.
- Trigger level* Trigger point of an alarm in the sensor's sensing element.
- Buzzer* The buzzer can be disabled.



The following tasks must only be executed by a person with proper education and knowledge of Ex-i devices.

We recommend, that when altering the settings the mains voltage is off or the device is initialized before the installation is executed.

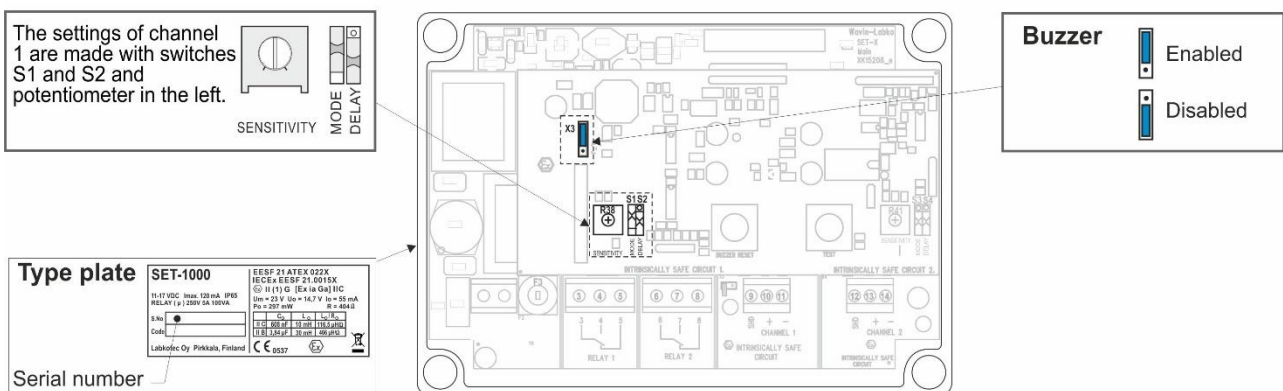

Figure 9. Altering settings

The settings are changed using the upper circuit board's switches (MODE and DELAY) and potentiometer (SENSITIVITY) and the lower circuit board's jumpers (Sensor selection and Buzzer). The switches are displayed in their default setting in the circuit board figure (figure 9).

OPERATING DIRECTION (MODE)

Switch S1 is used to set the operating direction. When the switch is in its low position, Alarm LED indicator as well as buzzer is on and relays de-energize when the liquid level is beneath the trigger level of the sensor (low level mode).

This setting is also used, when an alarm of an oil-layer on water is required.

When the switch is in its high position the Alarm LED indicator as well as buzzer will be on and relays de-energize when the liquid level is above the sensor's trigger level (high level mode).

OPERATIONAL DELAY SETTING (DELAY)

Switch S2 is used to set the operational delay of the device. When the switch is in low position relays operate and buzzer is on after 5 seconds after the level reaches trigger level, if the level still remains on the same side of the trigger level.

When the switch is in high position, the delay is 30 seconds.

Delays are operational in both directions (energizing, de-energizing).

Alarm LED follows the sensor current value and trigger level without delay. Fault LED has a fixed delay of 5 sec.

TRIGGER LEVEL SETTING (SENSITIVITY)

Trigger level setting is executed as follows:

1. Immerse the sensor's sensing element to the medium to the desired height – see sensor instructions, if needed.
2. Rotate the potentiometer so, that the Alarm LED is on and the relay de-energizes – please pay attention to the operational delay.
3. Check the function by lifting the sensor to the air and immersing it back to the medium.

4 TROUBLE-SHOOTING

Problem: MAINS LED indicator is off

Possible reason: Supply voltage is too low or the fuse is blown. Transformer or MAINS LED indicator is faulty.

- To do:**
1. Check if the two pole mains switch is off.
 2. Check the fuse.
 3. Measure the voltage between poles + and -.

Problem: FAULT LED indicator is on

Possible reason: Current in sensor circuit too low (cable break) or too high (cable in short circuit). The sensor might also be broken.

- To do:**
1. Make sure, that the sensor cable has been connected correctly to the SET-1000 control unit. See sensor specific instructions.
 2. Measure the voltage separately between the poles 10 and 11. The voltages should be between 10,3...11,8 V.
 3. If the voltages are correct, measure the sensor current. Do as follows:
 - 3.1 Disconnect sensor's [+] wire from sensor connector (pole 10).
 - 3.2 Measure short circuit current between [+] and [-] poles.
 - 3.3 Connect mA-meter as in figure 10.

Make a comparison to the values in Table 1. More detailed current values are to be found in the instructions of specific sensor's instructions.

- 3.4 Connect the wire back to the connector.

If the problem can not be solved with the above instructions, please contact Labkotec Oy's local distributor or Labkotec Oy's service.



Attention ! If the sensor is located in an explosive atmosphere, the multimeter must be Exi-approved !

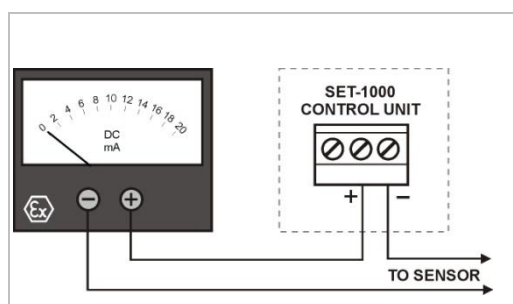

Figure 10. Sensor current measurement

	Channel 1 Poles 10 [+] and 11 [-]
Short circuit	20 mA – 24 mA
Sensor in the air	< 7 mA
Sensor in the liquid ($\epsilon_r . 2$)	> 8 mA
Sensor in the water	> 10 mA

Table 1. Sensor currents

5 REPAIR AND SERVICE

The mains fuse (marked 315 mA) can be changed to another glass tube fuse 5 x 20 mm / 315 mA complying EN IEC 60127-2/3. Any other repair and service works on the device may be carried out only by a person who has received training in Ex-i devices and is authorized by the manufacturer.

In case of queries, please contact Labkotec Oy's service.

6 SAFETY INSTRUCTIONS



SET-1000 level switch must not be installed in explosive atmosphere. Sensors connected to it may be installed in explosive atmosphere zone 0,1 or 2.

In case of installations in explosive atmospheres the national requirements and relevant standards as EN IEC 60079-25 and/or EN IEC 60079-14 must be taken into account.





If electrostatic discharges can cause hazards in the operating environment, the device must be connected into equipotential ground according to requirements with regards to explosive atmospheres. Equipotential grounding is made by connecting all conductive parts into same potential e.g. at the cable junction box. Equipotential ground must be earthed.



When executing service, inspection and repair in explosive atmosphere, the rules in standards EN IEC 60079-17 and EN IEC 60079-19 about instructions of Ex-devices must be obeyed.

APPENDICES

Appendix 1 Technical data

SET-1000	
Dimensions	175 mm x 125 mm x 75 mm (L x H x D)
Enclosure	IP 65, material polycarbonate
Cable glands	4 pcs M16 for cable diameter 5-10 mm
Operating environment	Temperature: -25 °C...+50 °C Max. elevation above sea level 2,000 m Relative humidity RH 100% Suitable for indoor and outdoor use (protected from direct rain)
Supply voltage	11-17 VDC Fuse 5 x 20 mm 315 mA (EN IEC 60127-2/3) The device is not equipped with a mains switch
Power consumption	Max. 1,2 VA. Typical (no alarms) 0,9 VA.
Sensors	One Labkotec SET sensor
Max. resistance of the current loop between the control unit and a sensor	75 Ω. See more in appendix 2.
Relay outputs	Two potential-free relay outputs 250 V, 5 A, 100 VA Operational delay 5 sec or 30 sec. Relays de-energize at trigger point. Operation mode selectable for increasing or decreasing level.
Electrical safety	EN IEC 61010-1, Class II  , CAT II / III POLLUTION DEGREE 2
Insulation level Sensor / Mains supply voltage	375V (EN IEC 60079-11)
EMC	Emission Immunity EN IEC 61000-6-3 EN IEC 61000-6-2
Ex-classification Special conditions (X) ATEX IECEX	 II (1) G [Ex ia Ga] IIC (Ta = -25 °C...+50 °C) EESF 21 ATEX 022X IECEX EESF 21.0015X
Electrical parameters Characteristic curve of the output voltage is trapezoidal. Attention ! See appendix 2.	Um = 23 V Uo = 14,7 V Io = 55 mA Po = 297 mW R = 404 Ω IIC IIB Co = 608 nF Lo = 10 mH Lo/Ro = 116,5 μH/Ω Co = 3,84 μF Lo = 30 mH Lo/Ro = 466 μH/Ω
Year of manufacture See serial number from the type plate	xxx x xxxxx xx YY x where YY = year of manufacture (e.g. 19 = 2019)

Appendix 2 Electrical parameters

When installing the device, make sure that the electrical values of the cable between SET-1000 and sensor never exceed maximum electrical parameters.

The cabling between SET-1000 control unit and cable extension junction box / cable joint must be executed as in figure 4 / 8 Extension cable should be shielded paired twisted instrument cable.

Due to non-linear characteristics of the sensor voltage, the interaction of both, capacitance and inductance, must be taken into account. The table below indicates the connecting values in explosion groups IIC and IIB.

In explosion group IIA the values of the group IIB can be followed.

$$U_o = 14,7 \text{ V} \quad I_o = 55 \text{ mA} \quad P_o = 297 \text{ mW} \quad R = 404 \Omega$$

The characteristics of the output voltage is trapezoidal.

	Max. permissible value		Both Co and Lo	
	Co	Lo	Co	Lo
II C	608nF	10 mH	568nF	0,15 mH
			458 nF	0,5 mH
			388 nF	1,0 mH
			328 nF	2,0 mH
			258 nF	5,0 mH
II B	3,84µF	30 mH	3,5 µF	0,15 mH
			3,1 µF	0,5 mH
			2,4 µF	1,0 mH
			1,9 µF	2,0 mH
			1,6 µF	5,0 mH

$$L_o/R_o = 116,5 :H/\Sigma \text{ (IIC)} \text{ and } 466 :H/\Sigma \text{ (IIB)}$$

Table 2. Electrical parameters

Maximum length of the sensor cable is determined by the resistance (max. 75 Ω) and other electrical parameters (Co, Lo and Lo/Ro) of the sensor circuit.

Example: Determining the maximum cable length

Instrument cable with following characteristics is used:

- DC resistance of a twin wire at + 20°C is approx. 81 Ω / km.
- Inductance is approx. 3 µH / m.
- Capacitance is approx. 70 nF/km

Influence of resistance Estimate for additional resistances in the circuit is 10 Ω. The max length of the cable is then $(75 \Omega - 10 \Omega) / (81 \Omega / \text{km}) = 800 \text{ m}$.

The influence of inductance and capacitance of a 800 m cable is:

Influence of inductance Total inductance is $0,8 \text{ km} \times 3 \mu\text{H}/\text{m} = 2,4 \text{ mH}$. The sum value of the cable and e.g. SET/OS2 sensor [$L_i = 30 \mu\text{H}$] is 2,43 mH. L/R ratio is thus $2,4 \text{ mH} / (75 - 10) \Omega = 37 \mu\text{H}/\Omega$, which is less than the maximum allowed value 116,5 µH/Ω.

Influence of capacitance Cable capacitance is $0,8 \text{ km} \times 70 \text{ nF}/\text{km} = 56 \text{ nF}$. Combined value of the cable and the e.g. SET/OS2 sensor [$C_i = 3 \text{ nF}$] is 59 nF.

When compared to the values in table 2, we can summarize that above values do not limit the use of this particular 800 m cable in explosion groups IIB or IIC.

Feasibility of other cable types and sensors for different distances can be calculated accordingly.

EU DECLARATION OF CONFORMITY

We hereby declare that the product named below has been designed to comply with the relevant requirements of the referenced directives and standards.

Product Measuring and control unit
SET-1000 and SET-2000 series

Manufacturer Labkotec Oy
Myllyhaantie 6
FI-33960 Pirkkala
Finland

Directives The product is in accordance with the following EU Directives
2014/30/EU Electromagnetic Compatibility Directive (EMC)
2014/35/EU Low Voltage Directive (LVD)
2014/34/EU Equipment for Potentially Explosive Atmospheres Directive (ATEX)
2011/65/EU Restriction of Hazardous Substances Directive (RoHS)

Standards The following standards were applied:

EMC: EN IEC 61000-6-2:2019
EN IEC 61000-6-3:2021
EN IEC 61000-3-2:2019
EN 61000-3-3:2013/A1:2019

LVD: EN 61010-1:2010/A1:2019/AC:2019-04

ATEX: EN IEC 60079-0:2018
EN 60079-11:2012

EC-type examination certificate: EESF 21 ATEX 022X.

Notified Body: Eurofins Expert Services Ltd, Notified Body number 0537.

The revised harmonised standards have been compared to the previous standard versions used in the original type certification and no changes in the "state of the art" apply to the equipment.

RoHS: EN IEC 63000:2018

The product is CE-marked since 2004.

Signature This declaration of conformity is issued under the sole responsibility of the manufacturer. Signed for and on behalf of Labkotec Oy.

Pirkkala, 8.9.2021

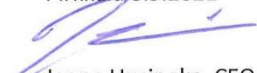

Janne Uusinoka, CEO
Labkotec Oy