

SET/TSH2 and SET/TSHS2

Capacitive level sensors



Installation and Operation Instructions



TABLE OF CONTENTS

1	GENERAL.....	3
2	CONNECTIONS AND INSTALLATION.....	4
3	ADJUSTING THE SWITCHING POINT	5
4	SERVICE AND REPAIR	6
5	TECHNICAL DATA.....	6

SYMBOLS



Warning / Attention



Pay special attention to installations at explosive atmospheres

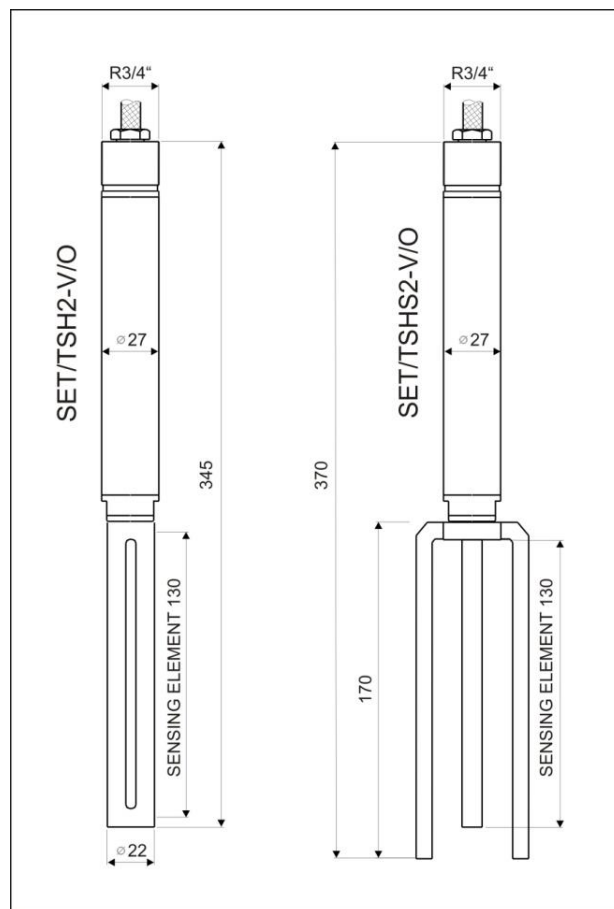

Fig. 1. SET/TSH2 and SET/TSHS2 dimensional drawings

1 GENERAL

SET/TSH2 and SET/TSHS2 are capacitive level detectors for liquids. V-versions are utilized with conductive liquids to indicate either low or high level, or for example oil/water interface in an oil separator. O-versions are convenient for use with non-conductive liquids, like oil, to indicate low or high level.

SET/TSH2 is a generic sensor and it suits for most applications. SET/TSHS2 is basically the same sensor with a fork as a counter-electrode. It is meant for more challenging environments, e.g. grease, heavy oil or clogging liquids.

The sensors are apparatus of equipment group II, category 1 G and can be installed in Zone 0/1/2 hazardous area.

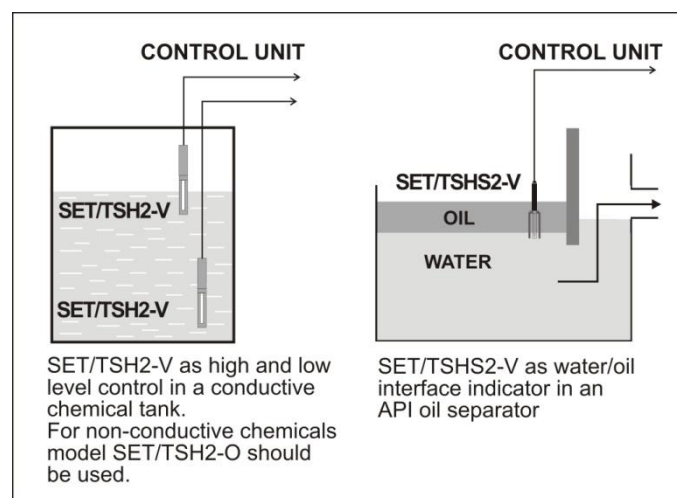

Fig. 2. Applications

2 CONNECTIONS AND INSTALLATION

The sensor is equipped with a shielded 3-wire cable. Wires 1 and 2 shall be connected to the corresponding connectors (1 = +, 2 = --) in the control unit. Wire 3 shall be connected to equipotential ground together with the shield of the cable.

Please refer also to the Installation and Operating Instructions of the control unit.

The sensor cable can be shortened or, when the control unit is located further away from the sensor, the cable can be extended with the junction box.

The sensor causes an alarm when its sensing element is half-immersed in the measureable liquid. The sensor can be installed by hanging it on its cable from a tank ceiling or it can be fixed in its place with an installation pipe equipped with a 3/4" inside thread. The fixed mounting prevents movement of the sensor when there is flow in the tank.



When installing the sensor into an explosion hazardous area (0/1/2), the following standards need to be followed; IEC/EN 60079-25 Electrical apparatus for potentially explosive atmospheres - Intrinsically safe electrical system "i", IEC/EN 60079-14 Electrical apparatus for explosive gas atmospheres.

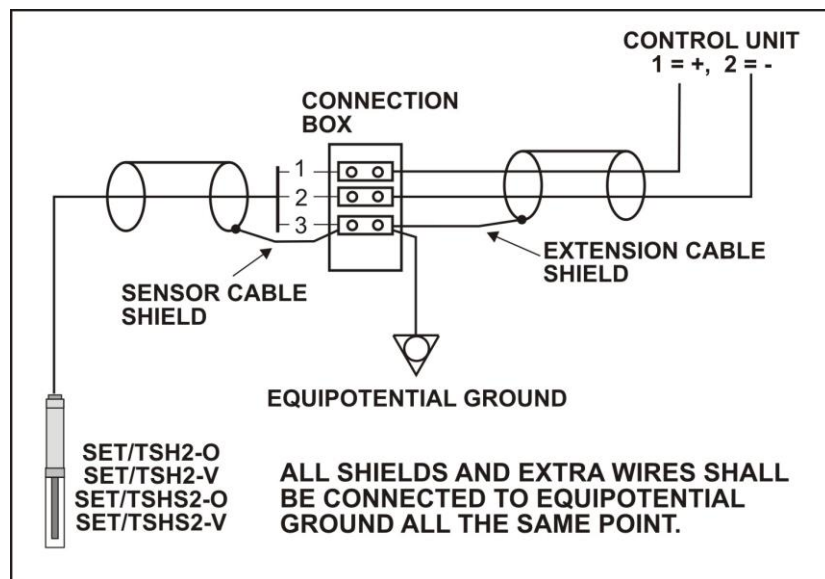

Fig. 3. Connection example

3 ADJUSTING THE SWITCHING POINT

1. Immerse the sensor into the liquid to be measured so that the sensing element of SET/TSH(S)2-O/V sensor is half-immersed in the liquid (the teflon coated rod acts as the sensing element) as in fig. 4.
2. Turn the sensitivity trimmer of the Labkotec SET control unit so that the alarm led just goes on.
3. Check the function by lifting and immersing the sensor couple of times into the liquid.

Check also the Installation and Operating Instructions of the control unit in case of special instructions for the particular application.

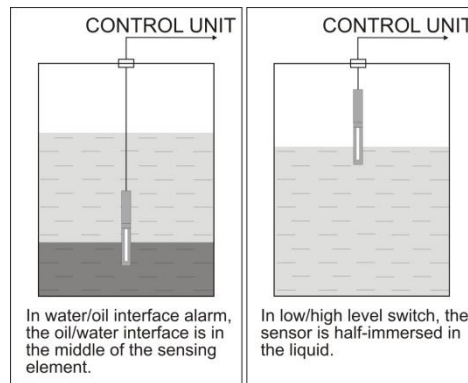

Fig. 4. Adjusting the switching point

IF THE SENSOR DOES NOT WORK



If the sensor is located in a hazardous area an Exi-classified multimeter must be used and the Ex-standards mentioned in chapter 5. SERVICE AND REPAIR must be followed.

Make sure that the Fault-led, which reports malfunction, is not on. If the Fault-led is on, repair any breakdown or short circuit in the electric circuit.

You can also check the function of the sensor by measuring its supply voltage (V) and current consumption (I) using a multimeter.

Measure voltage between control unit connectors + and -. The voltage should be 10.5...12 VDC.

Connect mA-gauge to the sensor circuit according to the figure below by disconnecting wire no. 1 from the control unit.

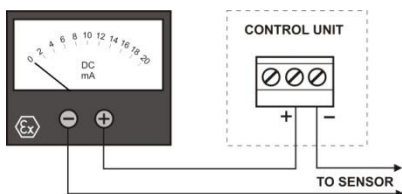

Fig. 5. Measuring the sensor current

Sensor current in different conditions:

	TSH2-O	TSHS2-O
sensor clean and entirely air	5...6,5 mA	5...6,5 mA
sensor entirely immersed in oil	9...12,5 mA	9...12,5 mA
	TSH2-V	TSHS2-V
sensor clean and entirely air	5...6 mA	5...6 mA
sensor entirely immersed in water	10...12 mA	10,5...12,5 mA

4 SERVICE AND REPAIR

The sensor must always be cleaned up and tested when emptying the tank or separator and when carrying out annual maintenance.

For cleaning, a mild detergent (e.g. washing-up liquid) and scrubbing brush can be used.



Service, inspection and repair of Ex-apparatus needs to be done according to standards EN IEC 60079-17 and EN IEC 60079-19.

5 TECHNICAL DATA

SET/TSH(S)2 sensor	
Control unit	Labkotec SET control units
Cable	Shielded oil-proof instrumentation cable 3 x 0.5 mm ² Ø 5,1mm. Standard length 5 m. Other lengths optional. Max. cable loop resistance 75 Ω.
Temperature Operational Safety	-25 °C...+60 °C -25 °C...+70 °C
Materials	AISI 316, Teflon, NBR-concentrate
EMC Emission Immunity	EN IEC 61000-6-3 EN IEC 61000-6-2
IP-classification Sensor Junction box	IP68 IP67
Ex-classification ATEX Special conditions (X)	 II 1 G Ex ia IIB T5 Ga VTT 03 ATEX 024X Ta = -25 °C...+70 °C The sensor cable can be extended with the junction box type LJB3-78-83 or LJB2-78-83.
Ex-connection values	Ui = 18 V I = 66 mA Pi = 297 mW Ci = 3 nF Li = 30 μH
Operating principle	Capacitive
Manufacturing year: Please see the serial number on the type plate	xxx x xxxxx xx YY x where YY = manufacturing year (e.g. 19 = 2019)

EU DECLARATION OF CONFORMITY

We hereby declare that the product named below has been designed to comply with the relevant requirements of the referenced directives and standards.

Product Level Sensor
SET/TSH2, SET/TSHS2, SET/TSH2/VP

Manufacturer Labkotec Oy
Myllyhaantie 6
FI-33960 Pirkkala
Finland

Directives The product is in accordance with the following EU Directives:
2014/30/EU Electromagnetic Compatibility Directive (EMC)
2014/30/EU Equipment for Potentially Explosive Atmospheres Directive (ATEX)
2011/65/EU Restriction of Hazardous Substances Directive (RoHS)

Standards The following standards were applied:

EMC: EN IEC 61000-6-2:2019
EN IEC 61000-6-3:2021

ATEX: EN IEC 60079-0:2018
EN 60079-11:2012

EC-type examination certificate: VTT 03 ATEX 024X.

Notified Body: VTT Expert Services Ltd, Notified Body number 0537.

The revised harmonised standards have been compared to the previous standard versions used in the original type certification and no changes in the "state of the art" apply to the equipment.

RoHS: EN IEC 63000:2018

Signature This declaration of conformity is issued under the sole responsibility of the manufacturer. Signed for and on behalf of Labkotec Oy.

Pirkkala 4.8.2021

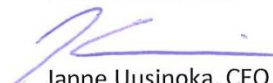
Janne Uusinoka, CEO
Labkotec Oy