

Labcom 221 BAT

Data transfer unit



Contents

1	General information about the manual	3
1.1	Conformity of the product	3
1.2	Limitation of liability	3
1.3	Used symbols	3
2	Safety and the environment	4
2.1	General safety instructions	4
2.2	Intended use	4
2.3	Transport and storage	4
2.4	Repair	4
2.5	Decommissioning and disposal	5
3	Product description	6
4	Installation and commissioning	7
5	Connections	8
5.1	Passive mA sensor	8
5.2	Active mA sensor	8
5.3	Switch output	9
5.4	Switch inputs	9
5.5	Example connections	10
5.5.1	Connection idOil-LIQ	10
5.5.2	Connection idOil-SLU	10
5.5.3	Connection idOil-OIL	11
5.5.4	Connection GA-SG1	11
5.5.5	Connection SGE25	12
5.5.6	Connection 1-wire temperature sensor	12
5.5.7	Connection DMU-08 and L64	13
5.5.8	Connection Nivusonic CO 100 S	13
5.5.9	Connection MiniSET/MaxiSET	14
6	Batteries	15
7	Troubleshooting FAQ	16
8	Technical specifications Labcom 221 BAT	17

1 General information about the manual

This manual is an integral part of the product.

- Please read the manual before using the product.
- Keep the manual available for the entire duration of the product's life span.
- Provide the manual to the next owner or user of the product.
- Please report any errors or discrepancies related to this manual before commissioning the device.

1.1 Conformity of the product

The EU declaration of conformity and the product's technical specifications are integral parts of this document.

All of our products have been designed and manufactured with due consideration to the essential European standards, statutes and regulations.

Labkotec Oy has a certified ISO 9001 quality management system and ISO 14001 environmental management system.

1.2 Limitation of liability

Labkotec Oy reserves the right to make changes to this user guide.

Labkotec Oy cannot be held liable for direct or indirect damage caused by neglecting the instructions provided in this manual or directives, standards, laws and regulations regarding the installation location.

The copyrights to this manual are owned by Labkotec Oy.

1.3 Used symbols

Safety related signs and symbols



DANGER!

This symbol indicates a warning about a possible fault or danger. In case of ignoring the consequences may range from personal injury to death.



WARNING!

This symbol indicates a warning about a possible fault or danger. In case of ignoring the consequences may cause personal injury or damage to the property.



CAUTION!

This symbol warns of a possible fault. In case of ignoring the device and any connected facilities or systems may be interrupted or fail complete.

2 Safety and the environment

2.1 General safety instructions

The plant owner is responsible for the planning, installation, commissioning, operation, maintenance and disassembly at the location.

Installation and commissioning of the device may be performed by a trained professional only.

Protection of operating personnel and the system is not ensured if the product is not used in accordance with its intended purpose.

Laws and regulations applicable to the usage or the intended purpose must be observed. The device has been approved for the intended purpose of use only. Neglecting these instructions will void any warranty and absolve the manufacturer from any liability.

All installation work must be carried out without voltage.

Appropriate tools and protective equipment must be used during installation.

Other risks at the installation site must be taken into account as appropriate.

2.2 Intended use

Labcom 221 GPS is primarily intended for transferring measurement, accrual, positioning, alarm and status information to the LabkoNet server from locations where there is no fixed power supply or installing it would be too expensive.

An LTE-M / NB-IoT network must be available for the device for data transfer. An external antenna can also be used for data transfer. The positioning functionalities require a satellite connection to the GPS system. The positioning (GPS) antenna is always internal, and there is no support for an external antenna.

A more specific description of the product's operation, installation and use is provided later in this guide.

The device must be used in accordance with the instructions provided in this document. Other use is counter to the product's purpose of use. Labkotec cannot be held liable for any damage caused by using the device in violation of its purpose of use.

2.3 Transport and storage

Check the packaging and its content for any possible damage.

Ensure that you have received all the ordered products and that they are as intended.

Keep the original package. Always store and transport the device in the original packaging.

Store the device in a clean and dry space. Observe the permitted storage temperatures. If the storage temperatures have not been presented separately, the products must be stored in conditions that are within the operating temperature range.

2.4 Repair

The device may not be repaired or modified without the manufacturer's permission. If the device exhibits a fault, it must be delivered to the manufacturer and replaced with a new device or one repaired by the manufacturer.

2.5 Decommissioning and disposal

The device must be decommissioned and disposed of in compliance with local laws and regulations.

3 Product description

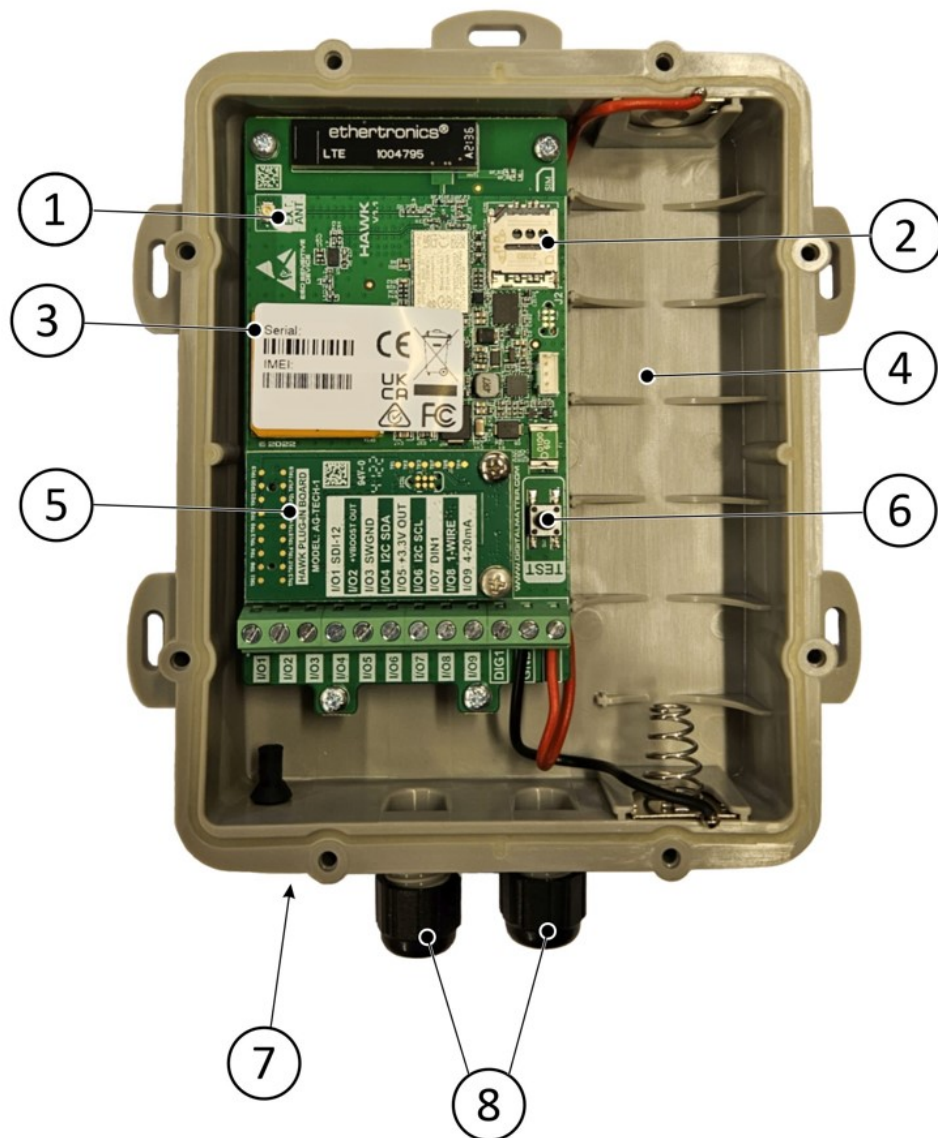

Figure 1 . Labcom 221 BAT product description

1. Internal external antenna connector
2. SIM card slot
3. Device serial number = device number (also on the device cover)
4. Batteries
5. Additional card
6. TEST button
7. External antenna connector (option)
8. Connection wire lead-throughs

4 Installation and commissioning

The device must be installed on a firm foundation where it is not at immediate risk of physical impacts or vibrations.

The device features screw holes for installation, as shown in the measurement drawing.

The cables to be connected to the device must be installed in such a way that prevents moisture from reaching the lead-throughs.

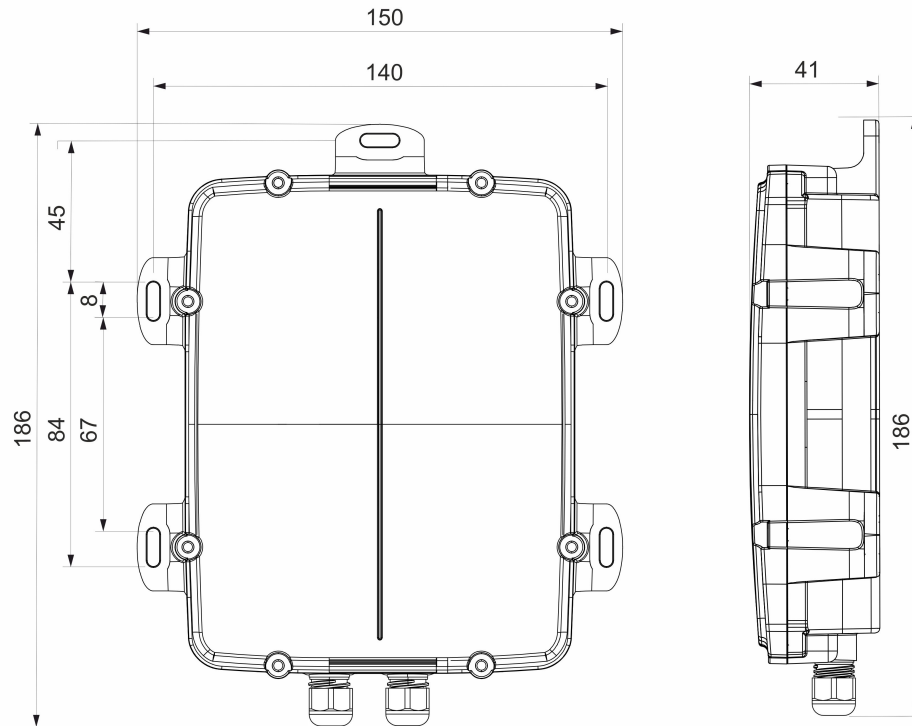

Figure 2 . Labcom 221 BAT measurement drawing and installation dimensions (mm)

The device features preset configurations and parameters and comes with a SIM card installed. DO NOT remove the SIM card.

Ensure the following in the context of commissioning before installing batteries, see Batteries on page 14 (1):

- The wires have been installed correctly and tightened firmly to the terminal strips.
- If installed, the antenna wire has been tightened properly to the antenna connector in the housing.
- If installed, the internal antenna wire installed in the device has stayed connected.
- All lead-throughs have been tightened to keep moisture out.

Once all of the above are in order, the batteries can be installed and the device cover can be closed. When closing the cover, make sure that the cover seal is seated correctly to keep dust and moisture out of the device.

After installing the batteries, the device automatically connects to the LabkoNet server. This is indicated by the circuit board LEDs flashing.

The commissioning of the device is confirmed with the LabkoNet server by checking that the device has sent the correct information to the server.

5 Connections



Read the section *General safety instructions* before installation.



Make the connections when the device is de-energised.

5.1 Passive mA sensor

Labcom 221 BAT supplies the measuring circuit of the passive transmitter/sensor with the operating voltage required by the sensor. The plus lead of the measuring circuit is connected to the voltage input of the Labcom 221 BAT (+Vboost Out, I/O2) and the ground lead of the circuit is connected to the analogue input of the device (4-20mA, I/O9). The end of the Protective Earth (PE) wire is insulated either with tape or shrink wrap and left free.

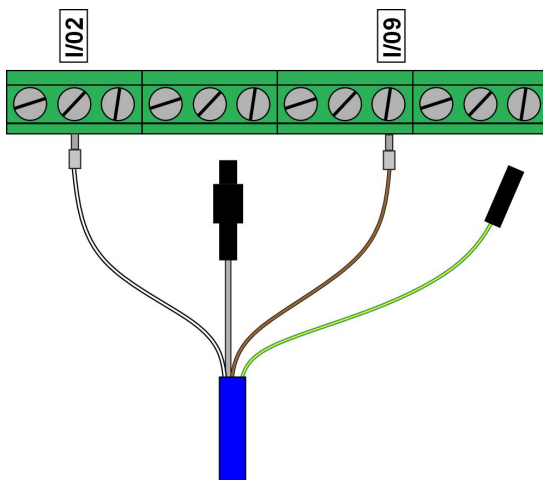

Figure 3 . Example connection.

5.2 Active mA sensor

The voltage to the measurement circuit of the active measurement transmitter/sensor is supplied by the transmitter/sensor itself. The measurement circuit's plus conductor is connected to the Labcom 221 GPS device's analogue input (4–20 mA, I/O9) and the circuit's grounding conductor is connected to the grounding connector (GND).

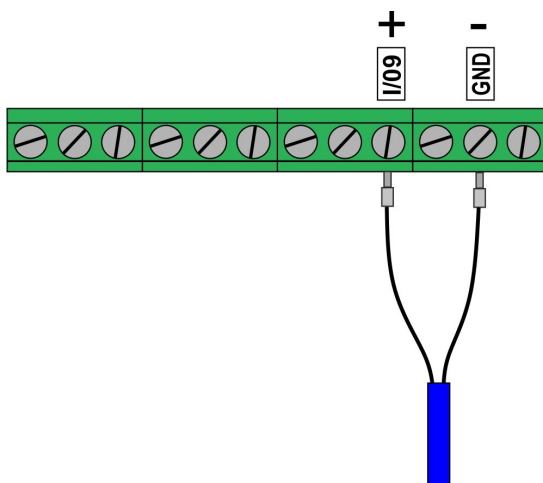

Figure 4 . Example connection

5.3 Switch output

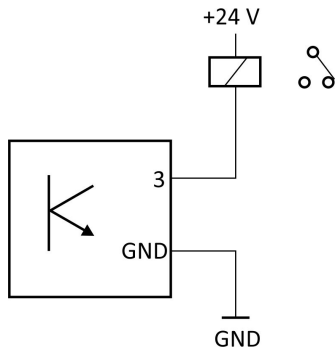
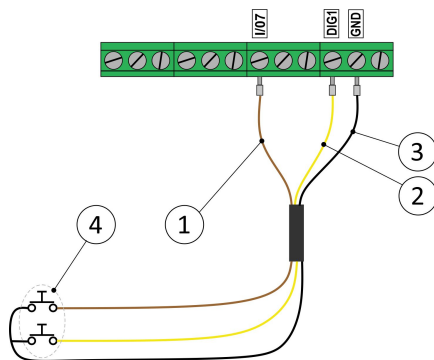

Figure 5 . Example connection

The Labcom 221 BAT device has one digital output. The approved voltage range is 0...40VDC and the maximum current is 1A. For larger loads, a separate auxiliary relay must be used, which is controlled by the Labcom 221 BAT.

5.4 Switch inputs



- 1 brown I/O7
- 2 yellow DIG1
- 3 black GND
- 4 Two separate switches

Figure 6 . Example connections

5.5 Example connections

5.5.1 Connection idOil-LIQ

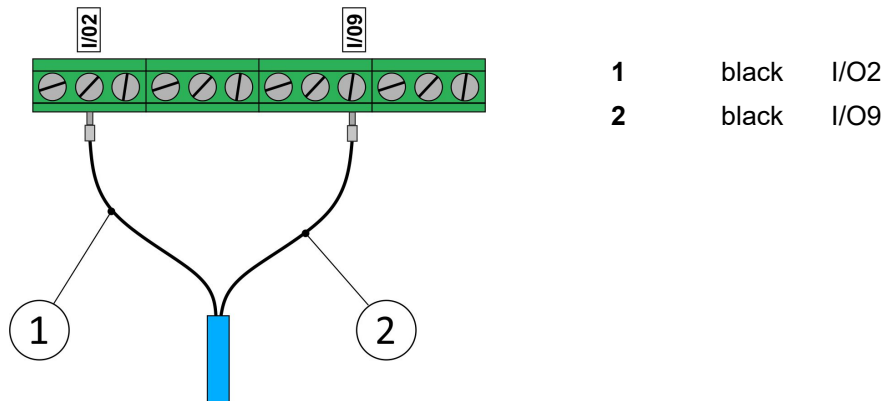

Figure 7 . idOil-LIQ sensor connection



The Labcom 221 BAT data transfer unit + idOil-LIQ sensor must not be installed in potentially explosive atmospheres.

5.5.2 Connection idOil-SLU

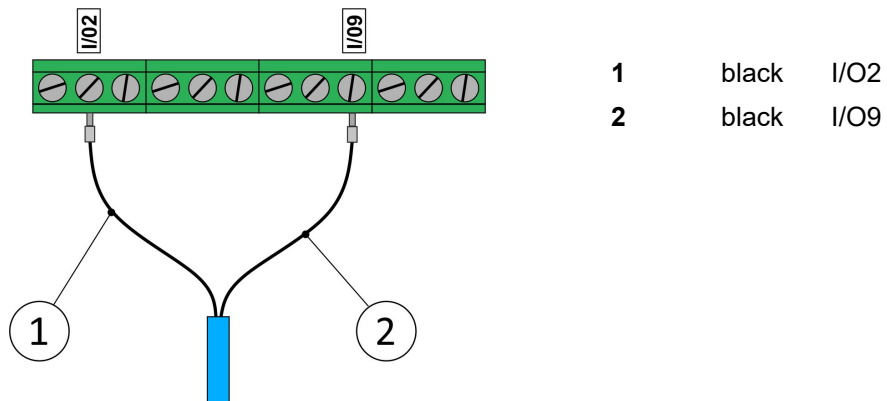

Figure 8 . idOil-SLU sensor connection



The Labcom 221 BAT data transfer unit + idOil-LIQ sensor must not be installed in potentially explosive atmospheres.

5.5.3 Connection idOil-OIL

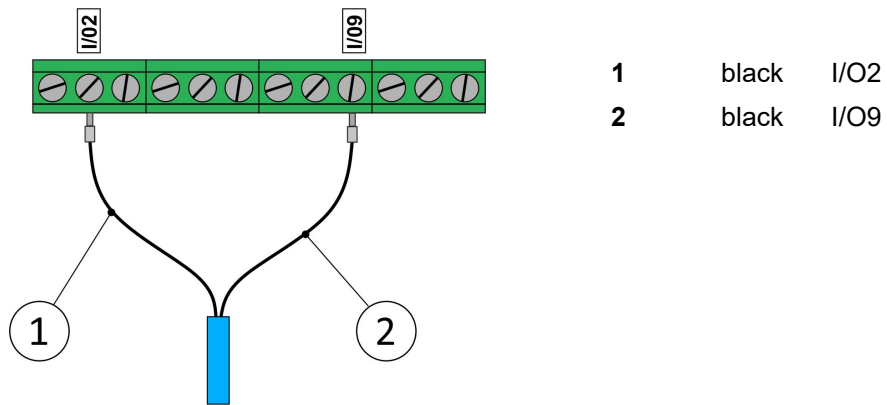

Figure 9 . idOil-OIL sensor connection



The Labcom 221 BAT data transfer unit + idOil-OIL sensor must not be installed in potentially explosive atmospheres.

5.5.4 Connection GA-SG1

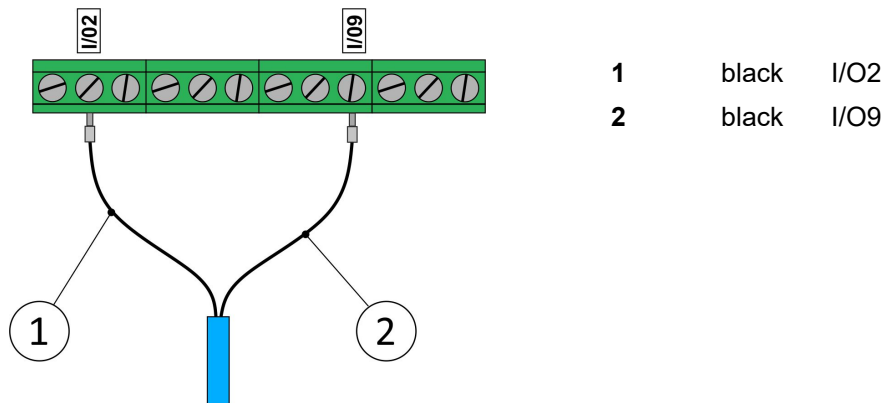

Figure 10 . GA-SG1 sensor connection

5.5.5 Connection SGE25

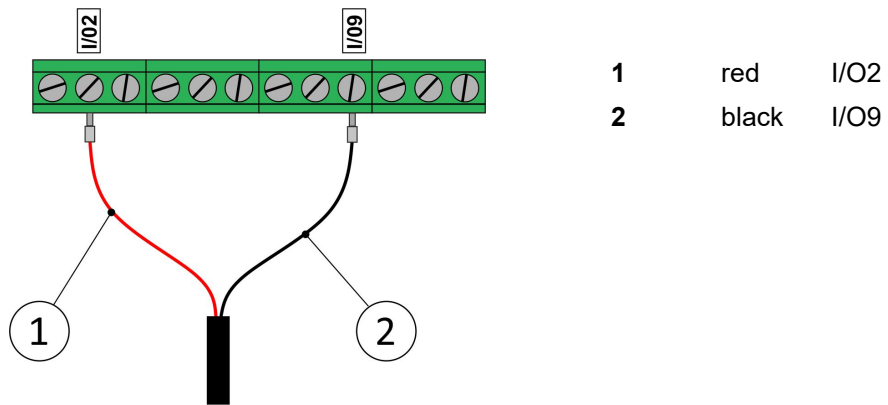

Figure 11 . SGE25 sensor connection

5.5.6 Connection 1-wire temperature sensor

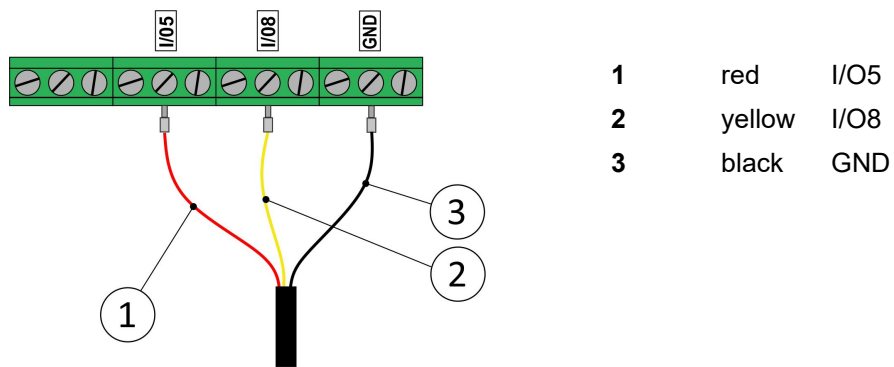

Figure 12 . 1-wire temperature sensor connection

5.5.7 Connection DMU-08 and L64

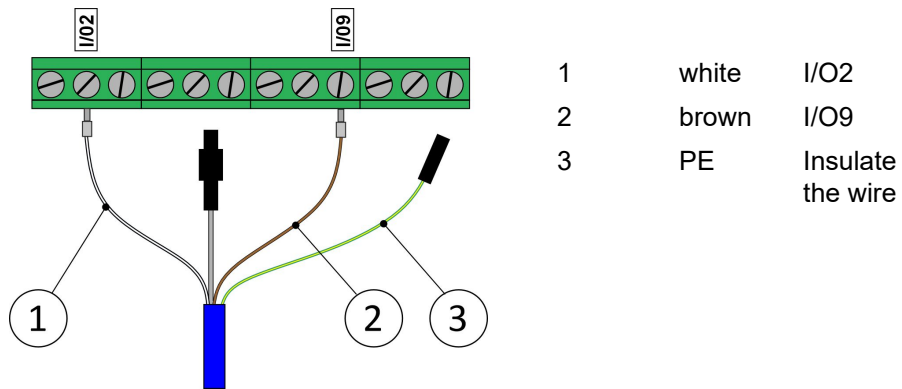

Figure 13 .DMU-08 and L64 sensors connection

If the DMU-08 sensor is to be connected, a cable extension (e.g. LCJ1-1) should be used to connect the DMU-08 sensor wires to the device and from which a separate cable is connected to the line connectors of the Labcom 221 BAT (not included). The end of the Protective Earth (PE) wire shall be insulated either by taping or shrink-wrap and left free.

5.5.8 Connection Nivusonic CO 100 S

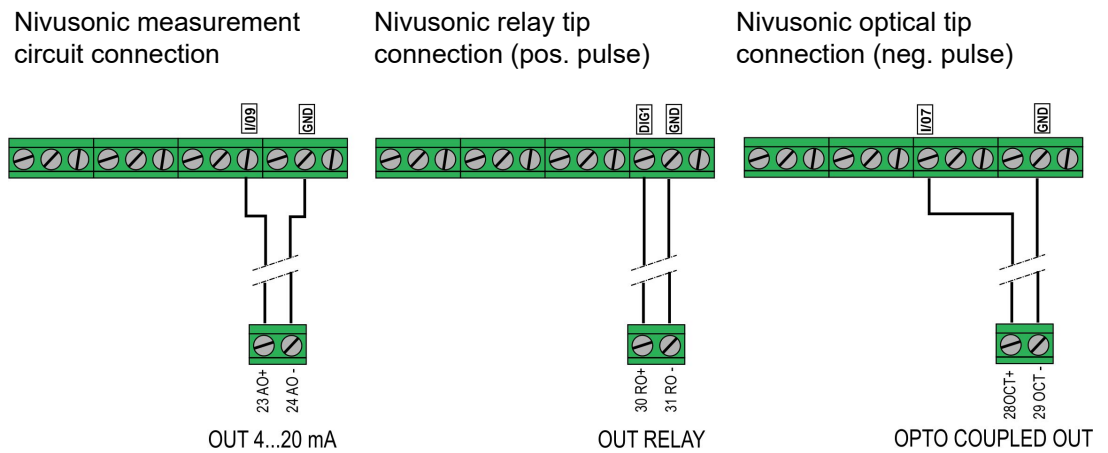

Figure 14 . Nivusonic CO 100 S connection

5.5.9 Connection MiniSET/MaxiSET

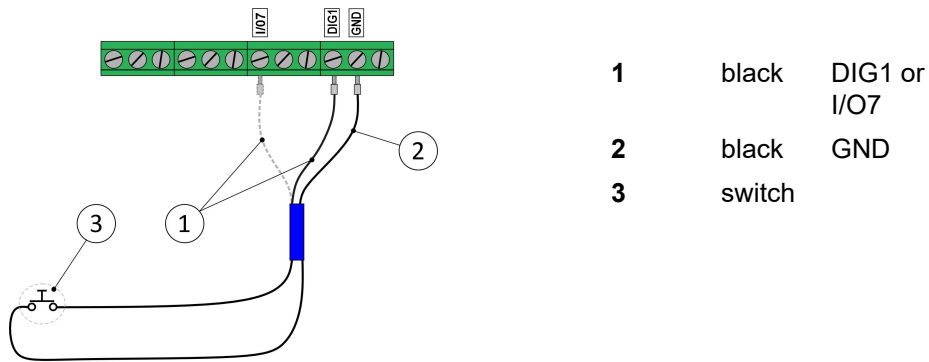

Figure 15 . Example connection

The sensor cable is connected to the instrument's ground terminal (GDN). The second sensor lead can be connected to the DIG1 or I/O7 connector. By default, the sensor operates as an upper limit alarm. If the sensor is to act as a lower limit alarm, the sensor float switch must be removed and reversed

6 Batteries

The Labcom 221 BAT is battery powered. The device is powered by two 3.6V lithium batteries (D/R20), which can provide up to more than ten years of operation. The batteries are easily replaceable.

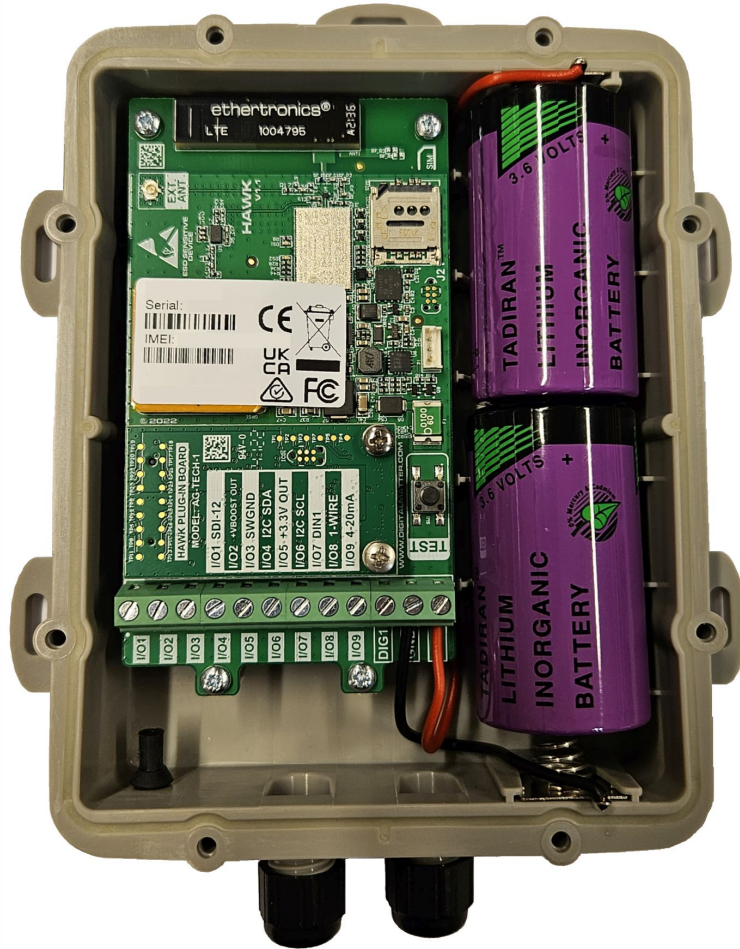

Figure 16 Labcom 221 BAT batteries

Battery information:

Type:	Lithium
Size:	D/R20
Voltage:	3.6V
Amount:	Two (2) pcs
Max. power:	At least 200mA

7 Troubleshooting FAQ

If the instructions in this section do not help with rectifying the problem, write down the device number and primarily contact the seller of the device or alternatively the e-mail address labkonet@labkotec.fi or Labkotec Oy's customer support +358 29 006 6066.

PROBLEM	SOLUTION
The device does not contact the LabkoNet server = connection failure	Open the device cover and press the TEST button on the right side of the circuit board (if the device is in the vertical position) for three (3) seconds. This forces the device to contact the server.
The device is connected to the server, but the measurement/accrual data is not updated to the server.	Make sure that the sensor/transmitter is in order. Check that the connections and conductors are tightened to the terminal strip.
The device is connected to the server, but the positioning data is not updated.	Change the installation location of the device so that it connects to the positioning satellite.

8 Technical specifications Labcom 221 BAT

TECHNICAL SPECIFICATIONS Labcom 221 BAT	
Dimensions	185 mm x 150 mm x 30 mm
Enclosure	IP 68 IP 67 when using an external antenna (option) IK08 (Impact protection)
Weight	310 g
Lead-throughs	Cable diameter 2.5–6.0 mm
Operating environment	Temperature: -30°C...+60°C
Supply voltage	Internal 2 pcs 3.6V Lithium batteries (D,R20) External 6–28 VDC, however over 5 W
Antennas (*)	GSM antenna internal/external GPS antenna internal
Data transfer	LTE-M / NB-IoT Encryption AES-256 and HTTPS
Positioning	GPS
Measurement inputs (*)	1 pc 4–20 mA +/-10 µA 1 pc 0–30 V +/- 1 mV
Digital inputs (*)	2 pcs 0–40 VDC, alarm and counter function for inputs
Switch outputs (*)	1 pc digital output, max 1 A, 40 VDC
Other connections (*)	SDI12, 1-wire, i2c-bus and Modbus
Approvals:	
Health and Safety	IEC 62368-1 EN 62368-1 EN 62311
EMC	EN 301 489-1 EN 301 489-3 EN 301 489-19 EN 301 489-52
Radio Spectrum Efficiency	EN 301 511 EN 301 908-1 EN 301 908-13 EN 303 413
RoHS	EN IEC 63000
Article 10(10) and 10(2)	No operating restrictions in any EU Member State.

(*) depends on the device configuration