

Data sheet

idOil Solar

idOil[®] Solar oil separator alarm system



Fulfills requirements of EN 858-1&2 standards

idOil Solar is a solar-powered alarm system for monitoring the levels of liquid hydrocarbon, sludge, or high levels in oil and sand separators, in locations where mains power is unavailable. The system components include solar panel, idOil-30 Battery control unit, charging controller and battery. It can be equipped with a beacon light and/or 3G modem. With the idOil Solar and applicable Labkotec sensors following alarms can be monitored:

- High liquid level alarm, when the liquid level in the oil separator rises excessively e.g. in an outlet blockage situation.
- Oil layer thickness alarm, when the oil separator's full capacity for oil or petrol has been reached.
- Sludge layer thickness alarm, when the sludge layer in the bottom of the separator has reached its maximum level.
- Separator leakage alarm, when the liquid level drops unexpectedly.

The idOil Solar remains deactivated most of the time, which means that it consumes very little power. The device initiates at predetermined measurement intervals, in order to perform the sensor measurements. When equipped with a 3G modem, the device also starts listening at predetermined intervals, to receive any possible setting commands and simultaneously reports measurement values.

In case of an alarm, idOil Solar will either initiate a flashing beacon, or sends a text message (SMS) to pre-set phone numbers, or both. All alarms are also visible locally, in the idOil control unit, when the control unit is activated.

The system's power consumption depends on the pre-set measurement and transmission intervals, as well as the number of alarms.

Technical data

Dimensions	200 mm x 400 mm x 132 mm (w x h x d)
Enclosure	Material: polycarbonate IP rating: IP43 with two ventilation devices
Weight	8,0 kg
Operating environment	Temperature -30 °C...+60 °C Max. elevation above sea level 3,000 m Relative humidity RH 100%
Battery	12 V DC, 7 Ah lead-acid battery
Power consumption	Max. 10 VA Typical 13,5 mA (on low-power mode)
Alarm indication	GSM text message AND/OR Xenon beacon AND/OR Potential free relay output (bistable latching relay)
Alarm and communication unit	idOil-30 Battery or idOil-30 Battery 3G
Sensors	idOil-OIL and/or idOil-SLU and/or idOil-LIQ
Ex-classification	Ⓔ II (1) G [Ex ia Ga] IIB
Special terms (X)	Ta = -30 °C...+60 °C
	ATEX, IECEx, UKEX
Exi connection values	Um = 30 V DC, Uo = 14.5 V, Io = 78 mA, Po = 367 mW, R = 243 Ω
Max impedance of the current loop between the control unit and a sensor	68 Ω
Manufacturing year:	xxxxxx x xxx xx YY x Where YY = manufacturing year (e.g. 18 = 2018)
Please see the serial number on the type plate.	

Features

- Selectable sensor combination with up to three sensors
- Polarity-free sensor connection
- Automatic sensor and sensor type detection
- Quick one touch commissioning
- Display for system status and alarm information in control unit inside
- Two fully configurable potential free relay outputs
- Alarm log
- Service and maintenance diary
- WLAN connection locally between control unit and laptop/tablet/smartphone to access the built in browser user interface for settings and configuration

Data sheet

idOil Solar

Application

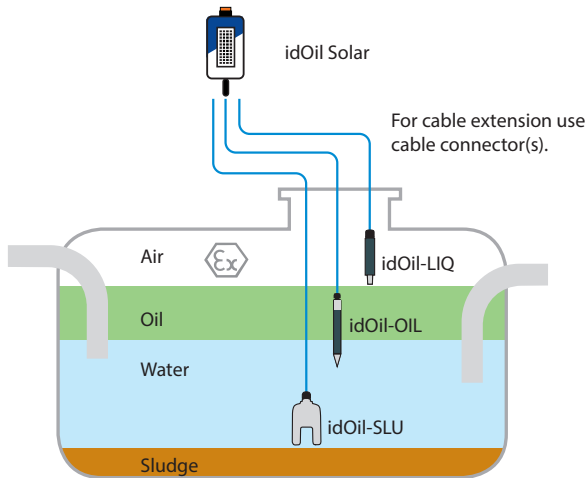

Settings, configurations and information via browser user interface



- System status view with current alarms
- Date and time settings
- Language selection
- Alarms log, downloadable
- Inspection settings
- Write inspection notes
- Inspection diary, downloadable
- Customer data input for display
- Alarm settings
- Sensor identification and naming
- Relay configuration
- Software update

Complete idOil Solar system

idOil Solar systems are available in complete packages. Choose a control unit and sensors and create a Solar system according to your needs. Below is an example of a typical idOil Solar system.

idOil-30 Solar LOS package consists of:

- Solar panel housing
- Battery
- Charging controller
- idOil-30 Battery or idOil-30 Battery 3G control unit
- idOil-LIQ high liquid level sensor
- idOil-OIL oil sensor
- idOil-SLU sludge sensor
- Cable connector LCJ1-3
- Mounting kits for control unit and sensor

Installation

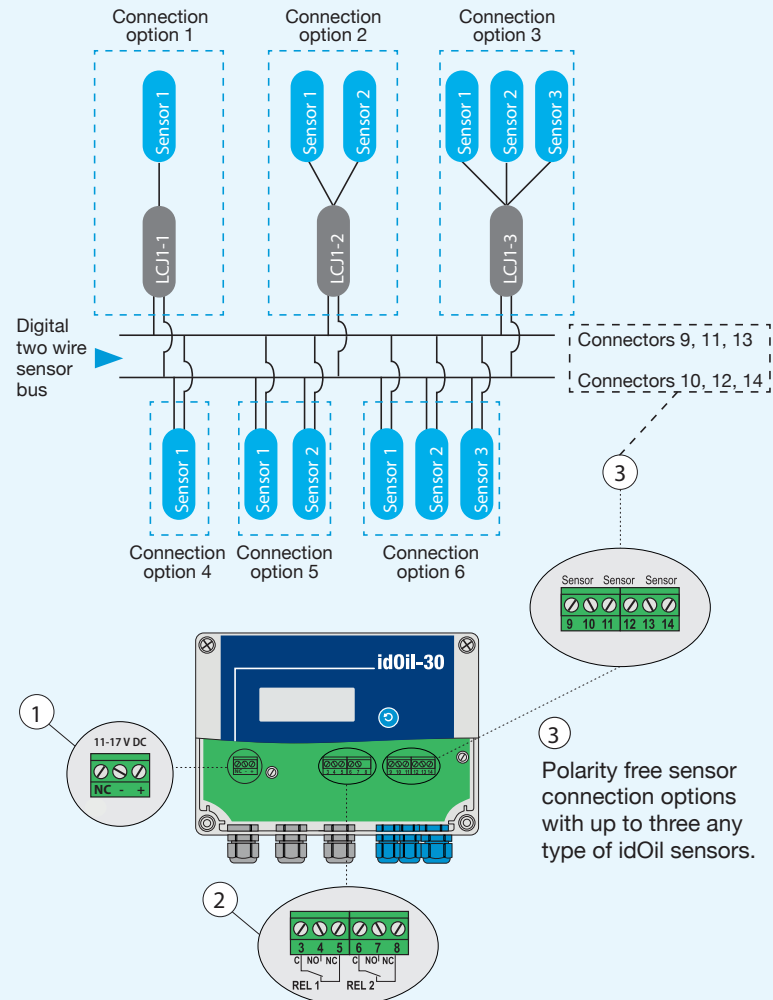

1 Supply voltage 11-17 V DC

- = Negative supply voltage
 - + = Positive supply voltage
- Max. supply cable 2.5 mm² (-, +) AWG 13

2 Relay output

- Relay 1
- 3 = Relay common contact
 - 4 = Contact that opens in an alarm situation
 - 5 = Contact that closes in an alarm situation
- Relay 2
- 6 = Relay common contact
 - 7 = Contact that opens in an alarm situation
 - 8 = Contact that closes in an alarm situation

3 Sensor connectors

- 9 = Sensor 1 connection 1
- 10 = Sensor 1 connection 2
- 11 = Sensor 2 connection 1
- 12 = Sensor 2 connection 2
- 13 = Sensor 3 connection 1
- 14 = Sensor 3 connection 2